

INSTALLATION INSTRUCTIONS

HT10 Outdoor Mount RH & RH/T Transmitter



IMPORTANT WARNINGS

- Only qualified trade installers should install this product
- This product is not intended for life-safety applications
- Do not install in hazardous or classified locations
- The installer is responsible for all applicable codes
- De-energize power supply prior to installation or service

PRODUCT APPLICATION LIMITATION:

Senva products are not designed for life or safety applications. Senva products are not intended for use in critical applications such as nuclear facilities, human implantable device or life support. Senva is not liable, in whole or in part, for any claims or damages arising from such uses.

INSTALLATION

1. Select an outdoor location under an eave on north side of building away from direct sunlight and rain exposure.
2. Mount product to building with supplied screws.
3. If installing with a conduit adapter, remove and replace the factory-installed cable gland.
4. Wire sensor as shown. Wiring for 2 and 3-wire 4-20mA signals and alternate terminal configurations are shown in next column.

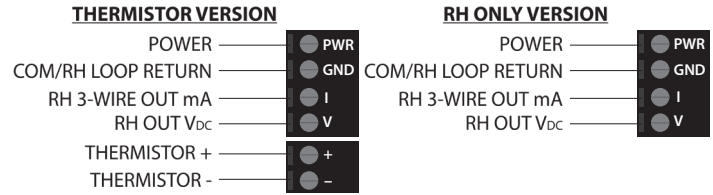
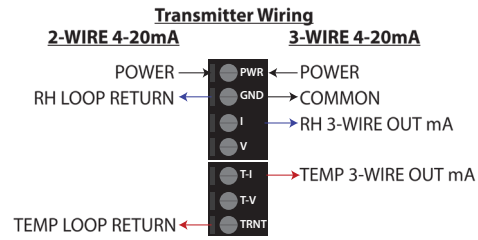
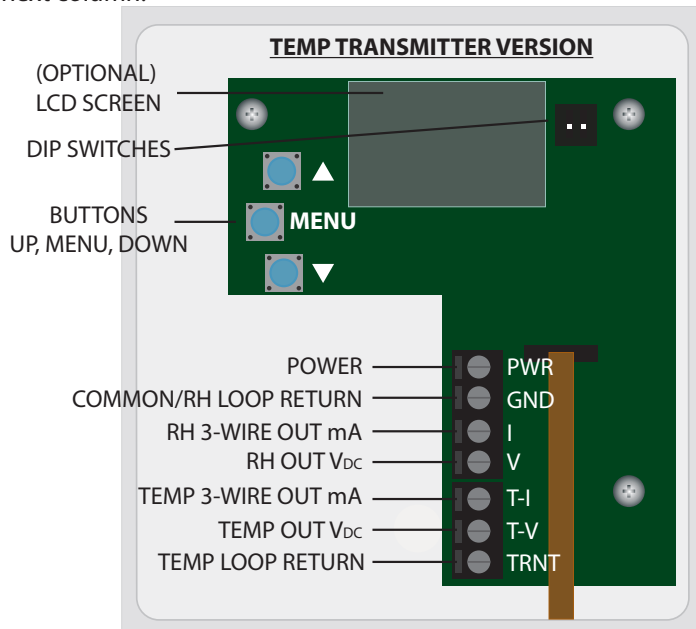

5. Set DIP switch positions to accommodate your application. DIP switch 2 only applies to units with transmitter temperature output selected.

ON	1	2	DIP	1	2
			UP	0-10V	-40-60C
			DN	0-5V	0-50C

6. Apply power to sensor.
7. Tighten cable gland firmly around wires. If installing with a conduit adapter, seal wire entry to prevent conduit air from affecting sensor readings or operation.
8. Close lid and tighten screw. Cover must be securely installed to prevent moisture from entering enclosure.

OPERATION

Press center MENU button to cycle between (1) the sensor readouts, (2) %RH offset, (3) temperature offset (transmitter version only), and (4) °F/°C display settings (LCD version only). The next press will return to the readout menu.

The lower ▼ arrow and upper ▲ arrow can be used to decrease or increase offset values in 0.1 increments up to ±5 (% or °) or choose between °C and °F.

If no LCD is present, the same menu structure applies except the °F/°C setting will not be accessible. A red LED will blink to indicate %RH offset setting and glow solid to indicate temperature offset setting in °F.

DIMENSIONS

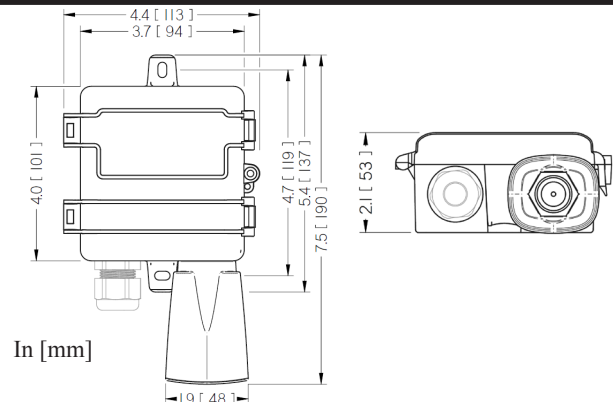

SPECIFICATIONS

Power supply	AC Supply/DC Supply	24VAC, 100mA max. / 12-30VDC, 50mA max.
Outputs	RH and Temperature (option)	3-wire 0-5V/10V ⁽⁴⁾ , 3-wire or 2-wire 4-20mA (Selectable)
Output scaling	RH	0-100%RH
	Temp. transmitter	32 to 122°F (0-50°C) or -40 to 140 °F (-40-60°C) (Selectable)
Thermistor/RTD options		See ordering table
Media filter		PBT with water vapor-permeable membrane
Relative Humidity	Accuracy	2% models: ±2% max 0 to 100% RH, ±1.5% typ 0 to 80% RH @25°C 3% models: ±3% max 0 to 100% RH, ±2% typ 0 to 100% RH @25°C
	Resolution	0.01% RH
	Hysteresis	±0.8% RH
	Repeatability	0.08 %RH
	Non-linearity	Factory linearized <1%RH
	Temperature coefficient	Fully compensated by on-board sensor
	Response time ⁽²⁾	8s
	Output update rate	0.5s
	Operating range	0 to 100%RH (non-condensing)
	Long term drift	<0.25%RH per year
	Recommended Operating conditions ⁽³⁾	41 to 140°F (5 to 60°C) @ 20% to 80% RH
	Temperature (Transmitter)	Accuracy
Resolution		0.01°C
Repeatability		0.04°C
Response time ⁽²⁾		2s
Output update rate		0.5s
Element Operating range		-40 to 140°F (-40 to 60°C)
Enclosure	Materials	ABS/Polycarbonate
	Dimensions	4.0"h x 4.4"w x 2.1"d (+2.8" Solar Shield)
	Enclosure Rating	IP20/NEMA 1 *Vent bottom of enclosure to achieve NEMA 3R Rating
	Unit Temp Rating	-40°F to 158°F (-40 to 70°C)

(1) One side of transformer secondary is connected to signal common. Dedicated transformer is recommended.

(2) Time for reaching 63% of reading at 25°C and 1 m/s airflow.

(3) Long term exposures to conditions outside normal range or high humidity may temporarily offset the RH reading (+3%RH after 60 hours).

(4) 15-30VDC/24VAC power supply voltage required for 10 volt output.

TROUBLESHOOTING

Symptom	Solution
No output	Check wiring. Ensure power supply meets requirements.
Temp or RH reading error	Verify control panel software is configured for correct output scaling.
	Verify accuracy of test instrument. Observe installation and calibration guidelines.
	Verify unit is securely installed on duct without excessive air leakage.
	Offset calibration only if necessary.
Sensor damage, contamination, or long-term drift	Replace sensor element. Consult factory for ordering information.

CALIBRATION

Senva RH sensors are factory calibrated to NIST traceable standards. No field calibration is necessary or recommended. However, to facilitate compliance with commissioning requirements field calibration offsets are allowed.

1. Locate calibration instrument and sensor in close proximity to each other in a controlled environment free of drafts, people, and equipment to reduce influence on RH and temperature.
2. Allow both readings to stabilize (10-30 minutes). Compare reading of sensor to calibration instrument, and calculate difference.
3. Refer to OPERATION section to change offsets as needed. Setting an offset of zero restores factory calibration.