

# INSTALLATION INSTRUCTIONS

## C-2320-L, Adjustable Mini Split-Core Digital Output

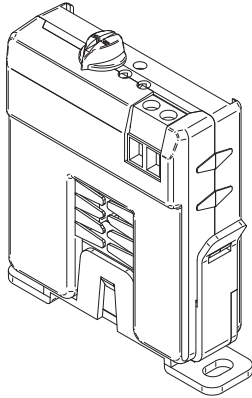

### DANGER

Failure to follow these instructions will result in death or serious injury.



Hazard of electrical shock, explosion, and arc flash

- Follow ALL requirements in NFPA 70E for safe work practices and for Personal Protective Equipment (USA) and other applicable local codes when installing this product
- Only qualified electrical personnel should install this product.
- Read, understand, and follow all instructions thoroughly
- Install only on insulated conductors
- Lock out and tag out all power sources prior to installation. Use properly rated voltage sensing instrument to determine no voltage is present



### WARNING

Failure to follow these instructions could result in death or serious injury.



Automated equipment may start without warning

- Equipment monitored/operated by this device may start without warning. Keep clear of apparatus at all times

### IMPORTANT WARNINGS

- Only qualified trade installers should install this product
- This product is not intended for life-safety applications
- Do not install in hazardous or classified locations
- The installer is responsible for all applicable codes
- This product must be installed in a suitable electrical enclosure

## INSTALLATION



Disconnect, lock out and tag out all power supplies during installation

1. Determine mounting location for the sensor near the conductor to be monitored. The sensor should be located AT LEAST 1/2" from any uninsulated conductor.
2. Sensor features a flexible iris which allows the sensor to hang on the conductor if local codes permit. A bracket is included for screw mounting or attaching to DIN rail. For screw mounting, drill two 3/32" pilot holes using the bracket as a template; ensure no drill shavings are present in enclosure. Attach bracket with screws provided.
3. Clamp sensor around INSULATED CONDUCTOR ONLY, 600VAC MAX to be monitored.
4. Snap the sensor into the mounting bracket.
5. Wire the output of the sensor to a control panel digital input loop not to exceed 30VAC/DC wetting voltage. Tighten terminals to 3.5 in-lb.

## CALIBRATION

1. Adjust knob on sensor to motor full load amperage (FLA) as indicated on motor nameplate or overload protection device. (See Tech Tips for precise calibration procedure.)

## WIRING EXAMPLES

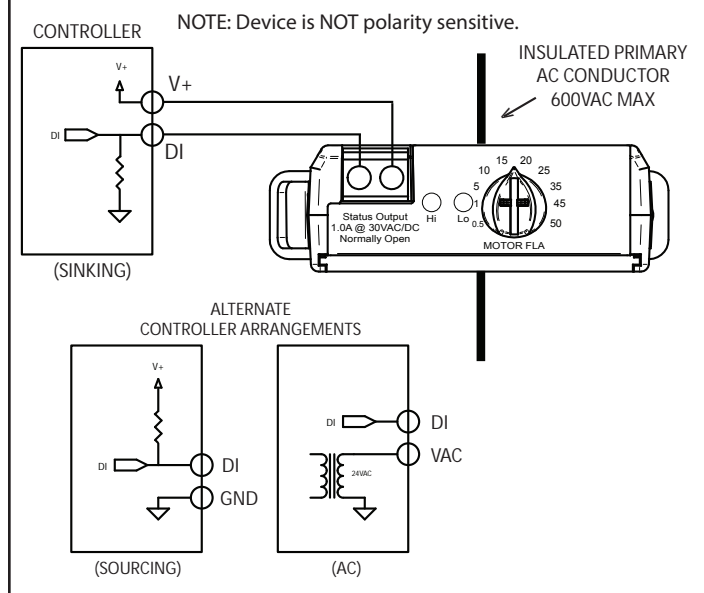

### PRODUCT APPLICATION LIMITATION:

Senva products are not designed for life or safety applications. Senva products are not intended for use in critical applications such as nuclear facilities, human implantable device or life support. Senva is not liable, in whole or in part, for any claims or damages arising from such uses.

Revised 9/15/2015 Document #152-0021-0B

## PRESET CALIBRATION (Typical)

Adjust knob on sensor to motor full load amperage (FLA) as indicated on motor nameplate or overload protection device.

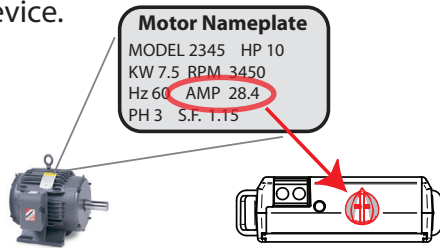

The sensor scale is pre-calibrated for motors operating at a **minimum of 75% FLA**.

On startup, the sensor output will close when monitored current exceeds 70% FLA, and open if current is below 60% FLA to indicate load loss (broken belt, coupling shear, etc.)

For lightly loaded (oversized) motors operating below 75% FLA, the sensor should be set to a proportionally lower FLA to ensure positive status detection and avoid nuisance alarms.

Smaller (less than 5HP) motors and/or lightly loaded motors may not have sufficient reduction in amperage (below 60% FLA) for the sensor to detect belt loss immediately. The sensor will detect the belt loss when the motor is restarted, as long as the unloaded motor current is below 70% FLA.

For improved performance on small and lightly loaded motors, consider the following options:

1. Use model C-2330 self-calibrating, microcontroller based sensor.
2. Perform conventional calibration.

Maximum surrounding air ambient, 60 ° C. For use in Pollution Degree 2 Environment.

Part Number	C-2320-L
Amperage Range	0.45A (on)~50A (200A Max.)
Output Type	NO, solid-state FET
Output Rating	1.0A@30VAC/DC Max.
Temperature Rating	-15~60 ° C
Insulation Class	600V RMS. For use on insulated conductors only! Use minimum 75 ° C insulated conductor
Sensor Power	Induced
Frequency Range	50/60Hz
Dimensions ( LxWxH)	2.94" x 2.23" x 0.82" (1.4" H with optional relay module)
Sensor Aperture	0.75"

## Conventional Calibration (High Accuracy)

**Follow all safety precautions outlined in this manual.** Follow ALL requirements in NFPA 70E for safe work practices and for Personal Protective Equipment (USA) and other applicable local codes when installing this product. **Read all warnings carefully.**

1. Adjust knob on sensor to maximum FLA. (Fully clockwise)
2. With motor operating normally, adjust knob SLOWLY counter-clockwise until Hi LED is lit.
3. Adjust knob a few degrees more to prevent nuisance alarms.

### Normal Operation

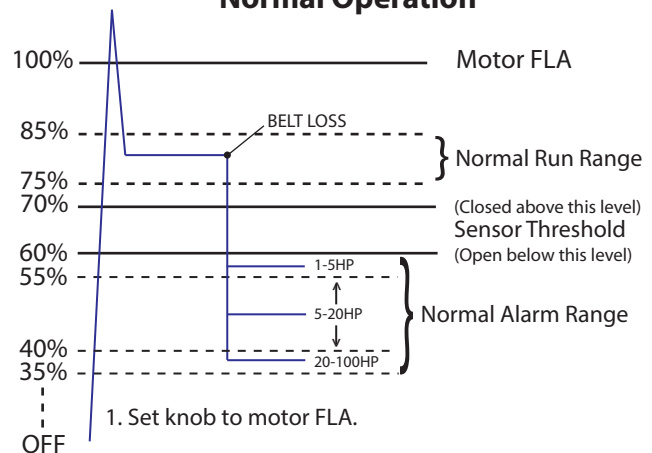

### Small / Lightly Loaded Motor Operation

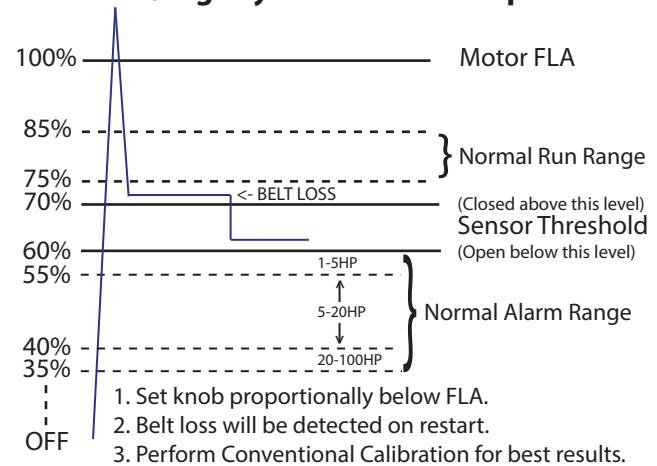

### Troubleshooting

Symptom	Causes	Remedy
Sensor output does not change state	Amperage is below sensor minimum threshold	Wrap monitored conductor through sensor. See Tech Tips
	Adjustment incorrect	See Conventional Calibration procedure
	Testing with ohm meter yields incorrect results	Solid state output may show approx. 1 ohm or less
	Incorrect control wiring	Ensure control loop voltage is present