

# INSTALLATION INSTRUCTIONS

## WD-1 Water Detector 9-30VAC/DC Power, Isolated N.C. switch output



### IMPORTANT WARNINGS

- Only qualified trade installers should install this product
- This product is not intended for life-safety applications
- Do not install in hazardous or classified locations
- The installer is responsible for all applicable codes
- De-energize power supply prior to installation or service

### DIMENSIONS

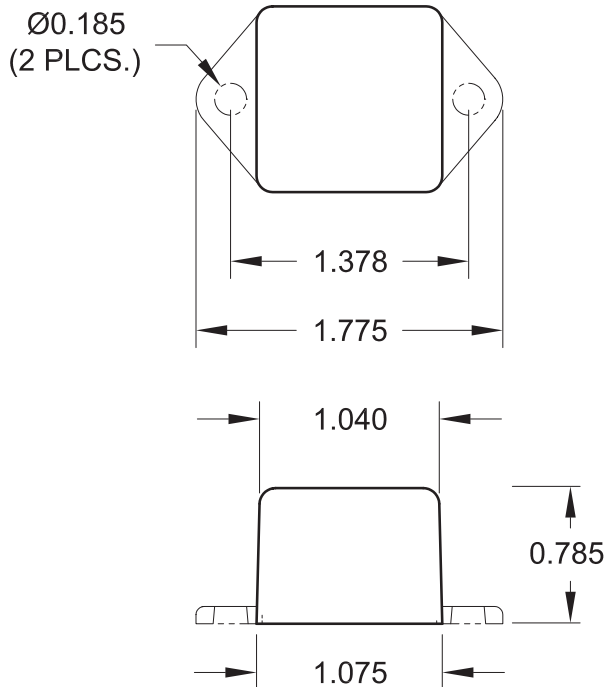

### INSTALLATION

1. Install sensor in the area to be monitored such that probe pins will contact collected water.
2. Fasten sensor with screws provided, or other means.
3. Wire sensor as follows:

RED = Power Supply 9-30VAC/DC  
BLACK = Ground/Common

WHITE = N.C. (Form B) Switch  
GREEN = N.C. (Form B) Switch

Switch contact is electrically isolated from power supply.

### OPERATION

Switch output opens when sensing probe pins are bridged by water.

Water resistance must be less than 1,000k (1M) ohms. Nearly all water supplies contain sufficient contaminants to trigger the sensor including: Filtered, Tap, Rain, Condensate, Melted Ice, Detergent, and Salt.

Not suitable for detecting distilled water.

Sensing probes utilize alternating current sensing (even when powered by DC current) to prevent electrolysis and oxidation of the sensing probes.

### SPECIFICATIONS

Power Supply	9-30VAC/DC, 10mA Max.
Output	N.C. (Form B) Solid State Relay, Isolated
Output Rating	30VAC/DC, 0.1A (100mA) Max.
Sensing	Gold plated electrodes
Operating Environment	-20 to 80degC

### PRODUCT APPLICATION LIMITATION:

Senva products are not designed for life or safety applications. Senva products are not intended for use in critical applications such as nuclear facilities, human implantable device or life support. Senva is not liable, in whole or in part, for any claims or damages arising from such uses.