

INSTALLATION INSTRUCTIONS

TG SERIES

BACnet/Modbus CO/NO2 Sensor

PRODUCT IDENTIFICATION

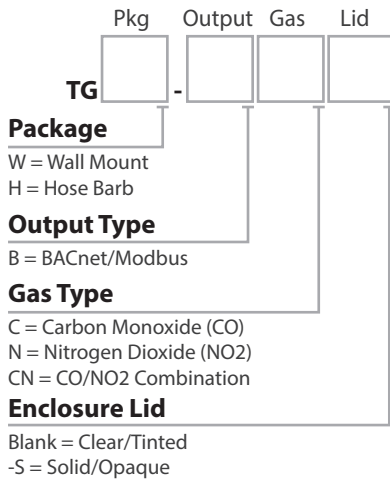

! WARNING

- Only qualified trade installers should install, program, maintain and test system incorporated therein. Installer is responsible for compliance of all applicable codes.
- Read, understand, and follow instructions thoroughly.
- The unit and associated systems require routine test and maintenance as prescribed in the TG Series User's Manual section 'Periodic Test and Maintenance'
- Do not install in hazardous or classified locations.
- De-energize power supply prior to installation.
- CO/NO2 sensors should not be used as a substitute for proper installation, use, or maintenance of CO/NO2 emitting equipment.
- This CO/NO2 sensor is designed to detect conditions that could result in acute effects of carbon monoxide or nitrogen dioxide exposure. It will not fully safeguard individuals with specific medical conditions. If in doubt, consult a medical practitioner.

LIMITATION OF LIABILITY

Senva's liability, whether in contract, in tort, under any warranty, in negligence or otherwise shall not exceed the amount of the purchase price paid by the purchaser for the product. Under no circumstances shall Senva be liable for special or consequential damages.

FEATURES

Visual/Audible Indicators - Standard LCD, LED indicators (green, yellow, red), audible alarm.

Supports BACnet and Modbus - Each TG unit supports BACnet MS/TP, Modbus RTU and Modbus ASCII.

Auto-Configuring Devices - TG Series automatically detects network baud rate, serial format, protocol and self-addresses!

Dual Gas Monitoring - Sensor can accommodate CO, NO2 or both CO and NO2 in one enclosure. Sensor can be expanded in field by adding additional CO or NO2 elements.

Easy Quick Start - TG Series has 4 Quick Start configurations that modify fan and alarm relay settings to common ranges utilized in the field.

Faster Commissioning - Test Mode in the Quick Start options lowers relay and alarm thresholds for faster field commissioning.

INSTALLATION

1. Identify the package type (wall or hose barb) of the TG Series sensor. Follow the 'Wall Mount' or 'Hose Barb' installation instructions accordingly:

Wall Mount

Locate sensor near traffic areas, away from sources of ventilation or drafts. One sensor per 5000-7500 square feet is normally required (applies to CO and NO2 sensors).

Mount the sensor directly to conduit or fasten the unit securely to the wall with the appropriate fasteners best suited to your construction. (Max conduit size is 1/2" NPT)

Recommended Sensor Mounting Height is 5 feet for the CO, NO2 and CO/NO2 combination units. Check with local and state building codes to ensure sensor mounting height is in compliance.

Hose Barb

Mount sensor on or near duct. Secure using holes on enclosure.

Install and plumb pickup tubes (not included) as shown:

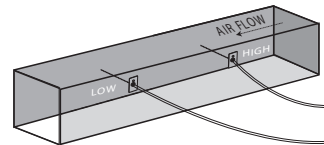

Connect tubes to hose barb fittings on sensor.

Recommended pickup tube length from duct to TG enclosure for a 90% change in 15 minutes is as follows:

Given Tube Length	Recommended Minimum Flow Velocity for 15 minute 90% change		
	inches	m/s	ft/min
6	1.3	261	3.0
12	1.4	270	3.1
18	1.4	279	3.2
24	1.6	317	3.6
30	1.7	335	3.8
36	1.7	340	3.9

2. Review the wiring callouts:

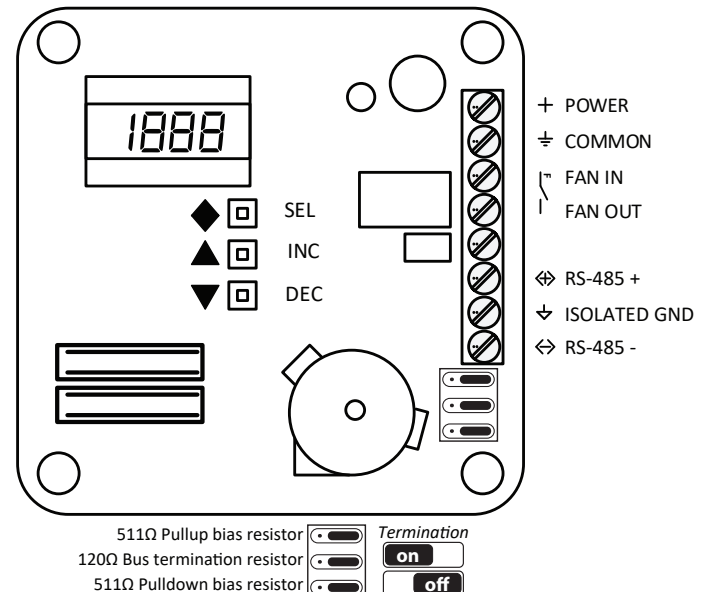

INSTALLATION (CONTINUED)

3. Utilize the daisy chain wiring diagram when applicable:

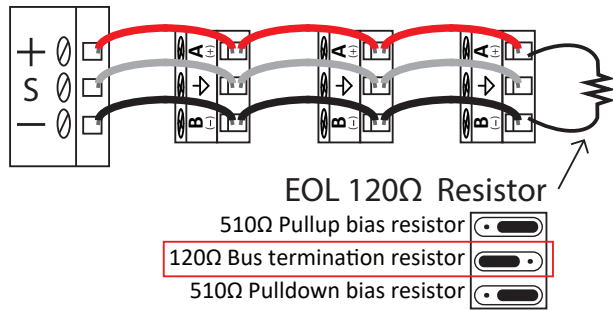

Use of appropriate shielded twisted pair wire (14-26 AWG) is recommended, per protocol specifications. Total wiring runs should not exceed 4000 feet, with a maximum of 128 devices (BACnet) or 32 devices (Modbus) in a single daisy chain.

Depending on the network configuration, it may be necessary to use the built in EOL (end-of-line) termination or biasing resistors on the TG Sensor.

4. For applications utilizing the fan relay, the diagram shows connection between one or multiple TG sensors wired to an exhaust fan using the fan setpoint relay(s). This function can be performed by a single TG sensor or a sequence of multiple TG sensors wired in parallel.

Ensure that the fan relay setpoints are uniform. The fan relays will activate if one or more of the sensors reach the setpoint.

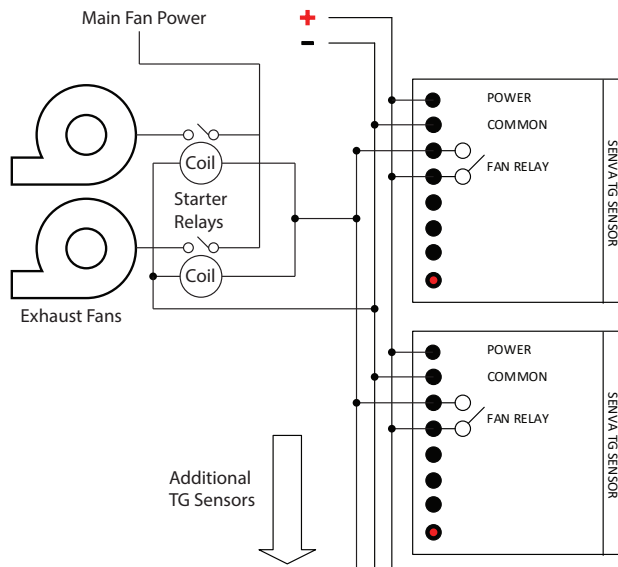

5. Apply power. Sensor may require up to 2 minutes of warmup time prior to displaying valid gas measurements.

6. Connect the TG Sensor(s) to an active network. The Senva TG Series can be used on both BACnet and Modbus networks. The default settings on the sensor includes auto-detection of protocol type, device address (BACnet only), serial format and baud rate. Each TG sensor ships with a default Modbus address. This process is further detailed in the respective *TG BACnet Protocol Guide* or *TG Modbus Protocol Guide*.

To manually adjust these parameters, utilize the *TG Series User's Guide*.

SUPPORTING DOCUMENTS

TG Series User's Guide

www.senvainc.com/TGUG

- Periodic Test and Maintenance
- Device Configuration
- Diagnostic Codes



TG BACnet Protocol Guide

www.senvainc.com/TGBN

- Automatic Configuration
- Object Reference



TG Modbus Protocol Guide

www.senvainc.com/TGMB

- Automatic Configuration
- Register Reference



OPERATION

The following section details factory defaults for LCD function, LED function, fan and alarm setpoints, fan relay and alarm functions, and the sensor element lifetime clock. These values can be modified from their default settings via the *TG Series User's Guide*.

LCD Function

The LCD is factory defaulted to toggle between readouts for each gas type populated on the board. Toggling can be modified using the *TG Series User's Guide*.

LED Function

The LED indicators function in sync with the fan relay and alarm status thresholds. LEDs will change state if either of the gases reach their fan or alarm setpoint.

Green	Normal readings below the fan setpoint
Yellow	Gas concentration above the fan setpoint and below the alarm setpoint
Red	Gas concentration level above the alarm setpoint

Fan and Alarm Setpoints

The fan and alarm setpoints are only applicable for elements populated on the board by the factory, or added in the field by the user.

Fan Relay Setpoint

CO: 25ppm

NO2: 1ppm

Alarm Setpoint

CO: 100ppm

NO2: 3ppm

OPERATION (CONTINUED)

Fan Relay/Alarm Status

Both the fan relay and alarm status are tied to the function of the LED indicators on each TG Series sensor. If a device has both the CO and NO2 elements populated on the board, then the fan relay and alarm status functions will activate if either of the gases reach their fan or alarm setpoint.

Status	LED	Fan Relay	Audible Alarm
Off	-	Closed	Silent
Below Fan Setpoint	Green	Open	Silent
Above Fan Setpoint	Yellow	Closed	Silent
Above Alarm Setpoint	Red	Closed	Silent
Above Alarm Setpoint for 30 minutes	Red	Closed	On

The duration of the fan relay and alarm buzzer operation are as follows. These values can also be modified from their default settings via the *TG Series User's Guide*.

Relay Activation Timing	
Fan Relay	Value
Minimum ON time	60 seconds
Minimum OFF time	60 seconds
Maximum OFF time	0 (inactive)
Audible Alarm Activation Timing	
Buzzer	Value
Delay	30 minutes
Minimum ON time	0 seconds
Minimum OFF time	0 seconds

Sensor Element Lifetime Clock

With 30 days remaining on the element lifecycle, the green LED will blink once every 10 seconds. This timer can be viewed using the *TG Series User's Guide*. Contact factory for replacement elements.

DIMENSIONS

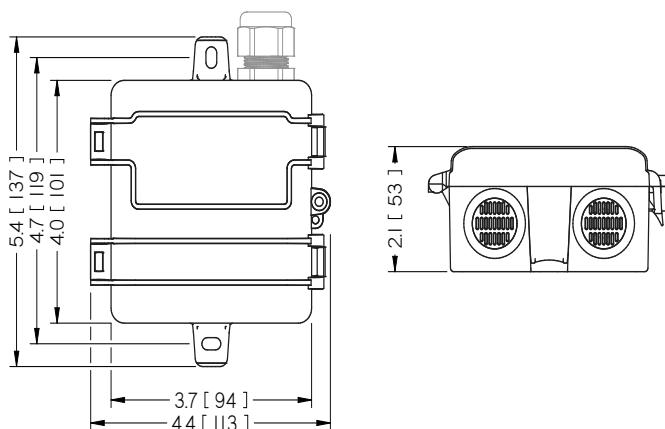

FAN/ALARM QUICK START

This section covers 'Quick Start' options for changing fan/alarm setpoint settings, including 'Test Mode' for commissioning.

Device will timeout back to normal operation after 60 seconds of no activity, so it is recommended to fully read through this section before proceeding into the LCD menu. (*This is an abbreviated section of the TG Series User's Guide. Do not attempt to change any other parameters without utilizing the full TG Series User's Guide found online at www.senvainc.com/TGUG*)

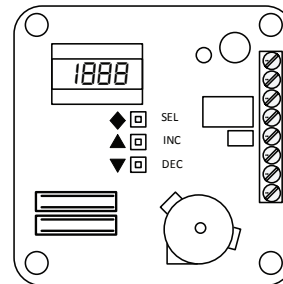

LCD Menu Buttons

- ◆ 'Select' button
- ▲ 'Increase/Up' button
- ▼ 'Decrease/Down' button

Quick Start

Quick Start allows the user to quickly select from four preconfigured parameters for the fan and alarm settings for CO and NO2. This includes a 'test mode' for commissioning.

Press the select button ◆ until *95tRrL*, scrolls across the LCD.

Press the select button ◆ again and LCD will read *A*. Choose from the table below which quick start parameter best fits your application and scroll to the setting using ▲ and ▼.

LCD	CO Fan	CO Alarm	NO2 Fan	NO2 Alarm	Buzzer Delay
<i>A</i>	25ppm	100ppm	1ppm	3ppm	30 minutes
<i>B</i>	15ppm	50ppm	0.7ppm	2ppm	30 minutes
<i>C</i>	35ppm	100ppm	1ppm	5ppm	30 minutes
<i>t5t</i>	5ppm	10ppm	0.5ppm	1ppm	2 minutes
<i>E5C</i>	Exits back to main User Menu screen				

Press the select button ◆ with your desired Quick Start displayed. After selecting the Quick Start parameter, device will display *10U*. Press the select button ◆ again. LCD menu will bounce back to your selected Quick Start selection. Use the ▲ and ▼ to scroll to *E5C* option and press the select button ◆. Display will now show *95tRrL*. Again, use the ▲ and ▼ to scroll to *E5C* option and press the select button ◆, or allow the device to timeout (approximately 60 seconds), to return to normal operation.

Important Note: If TG Sensor is configured into any of the 'Quick Start' options, including Test Mode, it will remain in that mode until further manual configuration.

SPECIFICATIONS

Power supply		15-30VDC/24VAC ⁽¹⁾ , 4w max, 120mA max.
Outputs	RS-485	BACnet MS/TP, Modbus RTU, Modbus ASCII
	Baud Rates	9600, 19200, 38400, 57600, 76800, 115200
	RS-485 Loading	1/4 unit
Fan Relay	Fan relay characteristics	N.C. 10A@125VAC, 5A@30VDC
	CO fan relay setpoint	25ppm (default), 0-1000ppm (menu selectable)
	NO2 fan relay setpoint	1ppm (default), 0-20ppm (menu selectable)
Display	3-1/2 digit LCD	Indicates CO ppm, NO2 ppm, Temp (menu selectable)
LED's	Green, Yellow, Red	Green = Normal, Yellow = Relay, Red = Alarm
Audible exposure alarm	85dB Piezo transducer	30 minutes above alarm setpoint per UL2034 (menu selectable)
CO Sensor Performance	Type	Electrochemical
	Accuracy	+/-5% of full scale ⁽²⁾ @ 20°C
	Reproducibility	<+/-2% of reading
	Response time (T90)	<30 seconds ⁽⁴⁾
	Certifications	UL2034 Recognized Component
	Long term stability	<+/-5% per year
	Life expectancy	>5 years
NO2 Sensor Performance	Type	Electrochemical
	Accuracy	+/-5% of full scale ⁽³⁾ @ 20°C
	Reproducibility	+/-2% (same day)
	Response time (T90)	<25 seconds ⁽⁴⁾
	Long term stability	<2% per month
	Life expectancy	>5 years
Operating Environment	Temperature, continuous	-20 to 40°C
	Temperature, intermittent	-30 to 55°C
	Humidity	15-95% continuous, 0-95% intermittent
Enclosure	Material	ABS/Polycarbonate
	Dimensions	4.0"h x 4.4"w x 2.1"d
	Conduit Opening	Tapped 1/2" NPT

(1) One side of transformer secondary is connected to signal common. Dedicated transformer is recommended.

(2) Carbon Monoxide full scale is 200ppm.

(3) Nitrogen Dioxide full scale is 20ppm.

(4) For TGH Installs, reference 'Installation' section on page 1 to account for time required to change enclosure air sample by 90% within 15 minute window based on pickup tube length and airflow velocity.

TROUBLESHOOTING

Symptom	Solution
No output	Check wiring. Ensure power supply meets requirements.
CO reading error	Sensor contaminated or at end of 5-year life. Replace sensor.
NO2 reading error	Sensor contaminated or at end of 5-year life. Replace sensor.
Relay Function	Verify setpoint. Verify test gas concentration. Cover sensor to prevent drafts and dilution during test.
LCD readout error	See TG Series User's Guide for full list of LCD diagnostic code definitions.